

30XW-VZE-A/ 30XWHVZE-A

WATER-COOLED VARIABLE-SPEED SCREW CHILLERS
WATER-SOURCED
VARIABLE-SPEED SCREW
HEAT PUMPS



AQUAFORCE
PUREtec

Nominal cooling capacity
448-1635 kW
Nominal heating capacity
523-1926 kW

LOW ENERGY CONSUMPTION
HIGH RELIABILITY
SAFE DESIGN
EASY AND FAST INSTALLATION
MINIMISED OPERATING SOUND LEVELS
ENVIRONMENTAL RESPONSIBILITY
DESIGNED TO SUPPORT GREEN BUILDING DESIGN



CARRIER participates in the ECP programme for
LCP-HP Check ongoing validity of certificate:
www.eurovent-certification.com

The 30XW-VZE/30XWHVZE water-sourced units are the premium solution for commercial and industrial applications where installers, consultants and building owners require maximum quality and optimal performances, especially at part load.

The 30XW-VZE/30XWHVZE units are designed to meet current and future requirements in terms of energy efficiency, versatility and compactness. They feature exclusive inverter-driven screw compressors - an evolution of the proven traditional Carrier twin-rotor screw compressor design. Other features include:

- The new SmartVu™ control
- Mechanically cleanable flooded heat exchangers
- Refrigerant R-1234ze(E) or R-515B

The 30XW-VZE/30XWHVZE range is splitted into two versions:

- 30XW-VZE for air conditioning applications
- 30XWHVZE for heating applications

As standard, the unit can provide an evaporator leaving water temperature down to -3 °C and can deliver up to 55 °C on the condenser side (60 °C for 1401A & 1601A models).

* Evaporator with aluminium jacket shown in the picture not standard - available as special order only

CUSTOMER BENEFITS

Low energy consumption

- The 30XW-VZE/30XWHVZE are designed for high performance both at full load and at part load.
 - Eurovent certified values per EN14511-3:2022: SEPR up to 10.7 and SEER up to 8.8
- High energy efficiency
 - Inverter-driven twin-rotor screw compressors allow precise capacity matching of building load changes and significantly reduce unit power input, especially at part-load.
 - Flooded multi-pipe heat exchangers for increased heat exchange efficiency.
 - Electronic expansion device permits operation at a lower condensing pressure and improved utilisation of the evaporator heat exchange surface.
- Optimised electrical performance
 - All 30XW-VZE/30XWHVZE units comply with class 3 of standard EN61800-3. Category C3 refers to industrial environments.
 - Inverter-driven motors ensure negligible start-up current (value is lower than the maximum unit current draw)

High reliability

- The 30XW-VZE and 30XWHVZE ranges offer increased global performance as well as Carrier's acclaimed product quality and reliability. Major components are selected and tested to minimize failures possibility, as well as many design choices have been taken in this perspective.
- Inverter-driven screw compressors
 - Industrial-type screw compressors with oversized bearings and motor cooled by suction gas (liquid cooled motor on 1401A & 1601A models).
 - The inverter is optimised for each compressor motor to ensure reliable operation and easy maintenance.
 - All compressor components are easily accessible on site minimising down-time.
- Refrigerant circuits
 - Two independent refrigerant circuits (from 1000 kW upwards); the second one automatically takes over, if the first one develops a fault, maintaining partial cooling under all circumstances.
 - All components have been selected and tested with R-1234ze(E) refrigerant and R-515B
- Evaporator
 - Electronic paddle-free flow switch to ensure prompt alarm in case of poor liquid flow rate. Auto-setting according to cooler size and fluid type.
- Auto-adaptive control
 - Control algorithm prevents excessive compressor cycling
 - Automatic compressor unloading in case of abnormally high condensing pressure or discharge temperature.
- Exceptional endurance tests
 - Partnerships with specialised laboratories and use of limit simulation tools (finite element calculation) for the design of critical components.
 - To ensure that the units arrive at customer sites in the same condition as they are when tested in the factory, Carrier tests the machine behavior while being moved along a 250 km trial. The test-route is based on a military standard and is the equivalent to 5000 km by truck in a normal road

Safe Design

- Specific polyol ester oil qualified by Carrier for using with R-1234ze(E) and R-515B to guarantee and maintain reliable bearing lubrication.
- Specific compressor gaskets compatible with R-1234ze(E) and R-515B, tested and validated by Carrier.
- New relief valves designed for operation with R-1234ze(E) and R-515B
- New control algorithms
- Specific documentation that contains all the installation, operation, maintenance and safety Instructions.
- No need of electrical cabinet ducted fresh air supply

Easy and fast installation

- Compact design
 - The 30XW-VZE/30XWHVZE units are designed to offer compact dimensions for easy installation.
 - With a width of approximately 1.25 m up to 1000 kW the units can pass through standard door openings and only require minimum floor space in the plant room.
- Simplified electrical connections
 - Transformer supply to the integrated control circuit (400/24 V)
- Simplified water connections
 - Victaulic connections on the evaporator and condenser
 - Practical reference marks for entering and leaving water connections
 - Possibility to reverse the heat exchanger water inlet and outlet at the factory
 - Possibility to modify the number of heat exchanger passes
- Fast commissioning
 - Systematic factory operation test before shipment
 - Quick-test function for step-by-step verification of the instruments, expansion devices and compressors.
 - Non flammable use possible when selecting option 330, Low GWP A1 R-515B Refrigerant

CUSTOMER BENEFITS

Minimised operating sound levels

- The inverter technology used for the compressor motors minimises noise levels at part load operation.
- Option 257 further reduces the global unit sound level with sound insulation on the components that are most subjected to radiated noise.

Environmental responsibility



- R-1234ze(E) long-term refrigerant solution
 - HFO refrigerant with nearly zero global warming potential (GWP < 2⁽¹⁾) and zero ozone depletion potential (ODP = 0).
 - Not impacted by the HFC phase-down plan in Europe (79% HFC reduction in EU member states at 2030 horizon)
 - Compliant with refrigerant regulation in Switzerland that bans the use of HFC refrigerant in large capacity air-conditioning equipment.

(1) According to AR6 from the IPCC (International Panel on Climate change)

- Leak-tight refrigerant circuit
 - Reduction of leaks as no capillary tubes and flare connections are used
 - Verification of pressure transducers and temperature sensors without transferring refrigerant charge
 - Discharge line shut-off valve (optional) and liquid line service valve for simplified maintenance.

Designed to support green building design

- A green building is a building that is environmentally sustainable and has been designed, constructed and is operated to minimise the total impact on the environment. The underlying principles of this approach: The resulting building will be economical to operate, offer increased comfort and create a healthier environment for the people who live and work there, increasing productivity.
- The air conditioning system can use between 30 and 40% of the annual building energy consumption. Selection of the right air conditioning system is one of the main aspects to consider when designing a green building. For buildings with a variable load throughout the year 30XW-VZE/30XWHVZE units offers a solution to this important challenge.
- A number of green building certification programs exist in the market and offer third-party assessment of green building measures for a wide variety of building types.
- The following example looks at how Carrier's new 30XW-VZE/30XWHVZE range helps customers involved in LEED® building certification.

30XW-VZE/30XWHVZE and LEED® certification

The LEED® (Leadership in Energy and Environmental Design) green building certification programme is a pre-eminent programme to rate the design, construction and operation of green buildings with points assigned in seven credit categories:

- Sustainable Sites (SS)
- Water Efficiency (WE)
- Energy & Atmosphere (EA)
- Materials & Resources (MR)
- Indoor Environmental Quality (IEQ)
- Innovation in Design (ID)
- Regional Priority (RP).

There are a number of different LEED® products.

While the strategies and categories assessed remain same, the point distribution varies to address different building types and application needs, for example according to New Construction, Schools, Core & Shell, Retail and Healthcare.

All programmes now use the same point scale:

110 Possible LEED® points

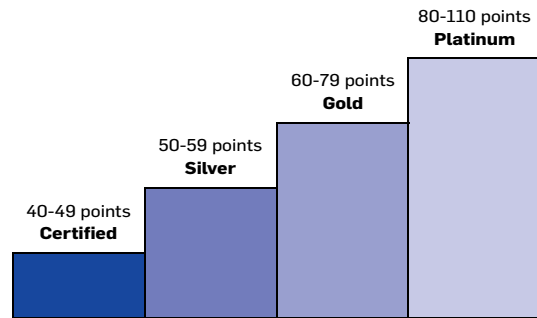

The majority of credits in LEED® rating systems are performance-based and achieving them is dependent on the impacts of each component or sub-system to the overall building.

While the LEED® green building certification programs do not certify products or services, the selection of the right products, systems or service programs is critical to obtain LEED® certification for a registered project, because the right products or service programmes can help meet the goals of green construction and ongoing operation and maintenance.

The choice of heating, ventilating and air conditioning (HVAC) products in particular can have a significant impact on LEED® certification, as the HVAC system directly impacts two categories that together influence 40% of the available points.

CUSTOMER BENEFITS

Overview of LEED® for new construction and major renovations

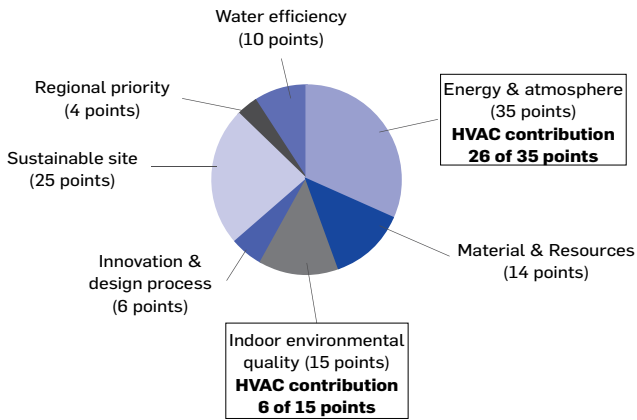

The new 30XW-VZE/30XWHVZE units from Carrier can assist building owners to earn LEED® points in particular in the Energy & Atmosphere (EA) credit category and help address the following prerequisites and credit requirements:

- **EA prerequisite 2: Minimum energy Performance**
The 30XW-VZE/30XWHVZE exceeds the energy efficiency requirements of ASHRAE 90,1-2007; therefore it complies with the prerequisite standard.
- **EA prerequisite 3: Fundamental Refrigerant Management**
The 30XW-VZE/30XWHVZE does not use chlorofluorocarbon (CFC) refrigerants thus satisfying the prerequisite statement.
- **EA credit 1: Optimise energy performance (1 to 19 points)**
Points for this credit are assigned depending on the energy cost reduction virtually achievable by the new building, compared to ASHRAE 90,1-2007 reference. The 30XW-VZE/30XWHVZE, which is designed for high performance especially during part load operation, contributes reducing the energy consumption of the building and therefore helps gaining points within this credit. In addition, the Carrier HAP (Hourly Analyses Program) can be used as an energy analyses program complying with the modeling requirements for this credit and produce reports that are easily transferable to LEED® templates.
- **EA credit 4: Enhanced refrigerant management (2 points)**
With this credit, LEED® awards systems that minimise the Ozone Depletion Potential (ODP) and Global Warming Potential (GWP) of the system. The 30XW-VZE/30XWHV-ZE uses R-1234ze(E) refrigerant with Global Warming Potential Index below 2 and therefore contributes toward satisfying this credit under LEED®.

NOTE: This section describes the prerequisites and credit requirements in LEED® for New Construction and is directly related to the 30XW-V-ZE/30XWHV-ZE. Other prerequisites and credit requirements are not directly and purely related to the air-conditioning unit itself, but more to the control of the complete HVAC system.

I-Vu®, Carrier's open control system, has features that can be valuable for:

- EA prerequisite 1: Fundamental commissioning of energy management system
- EA credit 3: Enhanced commissioning (2 points)
- EA credit 5: Measurements and verification (3 points).

NOTE: Products are not reviewed or certified under LEED®. LEED® credit requirements cover the performance of materials in aggregate, not the performance of individual products or brands. For more information on LEED®, visit www.usgbc.org.

TECHNICAL INSIGHTS

SmartVu™

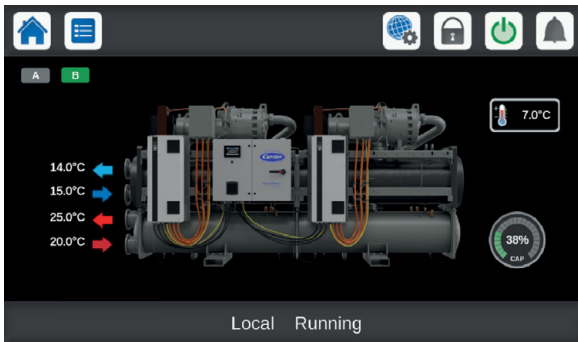

- New innovative smart control features :
 - An intuitive and user-friendly, coloured, 7" interface
 - 1 languages available on choice : EN, ES, FR, DE, NL, IT, PT, CN + one additional customer choice
 - Screen-shots with concise and clear information in local languages
 - Complete menu, customised for different users (end user, service personnel and Carrier-factory technicians)
 - Setpoint offset based on the outside air temperature
 - Safe operation and unit setting: Password protection ensures that unauthorised people cannot modify any advanced parameters
 - Simple and "smart" intelligence uses data collection from the constant monitoring of all machine parameters to optimise unit operation
 - Night-mode: Cooling capacity management for reduced
 - Noise level.
 - With hydraulic module: Water pressure display and water flow rate calculation.
- Energy management :
 - Internal time schedule clock controls chiller on/off times and operation at a second set-point
 - The DCT (Data Collection Tool) records the alarms history to simplify and facilitate service operations.
- Maintenance functions :
 - F-Gas regulation leak check reminder alert
 - Maintenance alert can be configured to days, months or hours of operation
- Advanced communication features :
 - Easy and high-speed communication technology over Ethernet (IP) to a centralised building management system
 - Access to multiple unit parameters.

Remote Management (Standard)

- Units with SmartVu™ control can be easily accessed from the internet, using a PC with an Ethernet connection. This makes remote control quick and easy and offers significant advantages for service operations
- Aquaforce with Greenspeed® Intelligence is equipped with an RS485 serial port that offers multiple remote control, monitoring and diagnostic possibilities. When networked with other Carrier equipment through the CCN (Carrier Comfort Network - proprietary protocol), all components form a HVAC system fully-integrated and balanced through one of the Carrier's network system products, like the Chiller System anager or the Plant System anager (optional).
- The chiller also communicates with other building management systems via optional communication gateways (BACnet, LON or Modbus).
- The following commands/visualisations are possible from remote connection:
 - Start/Stop of the machine
 - Dual set-point management: Through a dedicated contact is possible to activate a second set-point (example, unoccupied mode)
 - Demand limit setting: To limit the maximum chiller capacity to a predefined value
 - Water pump control: These outputs control the contactors of one/two evaporator water pumps.
 - Water pumps changeover (only with hydraulic module options): These contacts are used to detect a water pump operation fault and automatically change over to the other pump.
 - Operation visualisation: indication if the unit is operating or if it is in stand-by (no cooling load)
 - Alarm visualisation.

TECHNICAL INSIGHTS

Remote management (EMM option)

- The Energy management module (EMM) offers extended remote control possibilities:
- Room temperature: Permits set-point reset based on the building indoor air temperature (if Carrier thermostats are installed)
- Set-point reset: Allows reset of the cooling set-point based on a 4-20 mA or 0-10 V signal
- Demand limit: Permits limitation of the maximum chiller capacity based on 0-10 V signal
- Demand limit 1 and 2: Closing of these contacts limits the maximum chiller capacity to two predefined values.
- User safety: This contact can be used for any customer safety loop; opening the contact generates a specific alarm.
- Ice storage end: When ice storage has finished, this input permits return to the second set-point (unoccupied mode).
- Time schedule override: Closing of this contact cancels the programmed time schedule.
- Out of service: This signal indicates that the chiller is completely out of service.
- Chiller capacity: This analogue output (0-10 V) gives an immediate indication of the chiller capacity.
- Alert indication: This volt-free contact indicates the necessity to carry out a maintenance operation or the presence of a minor fault.
- Compressors running status: Set of outputs (as many as the compressors number) indicating which compressors are running.

Remote management (EMM option)

The Energy Management Module offers extended remote control possibilities:

- Room temperature: permits set-point reset based on the building indoor air temperature (with Carrier thermostat)
- Set point reset: ensures reset of the cooling set-point based on a 0-10 V signal
- Demand limit: permits limitation of the maximum chiller power or current based on a 0-10 V signal
- Demand limit 1 and 2: closing of these contacts limits the maximum chiller power or current to two predefined values
- User safety: this contact can be used for any customer safety loop; opening the contact generates a specific alarm
- Ice storage end: when ice storage has finished, this input permits return to the second set-point (unoccupied mode)
- Time schedule override: closing of this contact cancels the time schedule effects
- Out of service: this signal indicates that the chiller is completely out of service
- Chiller capacity: this analogue output (0-10 V) gives an immediate indication of the chiller capacity
- Alert indication: this volt-free contact indicates the necessity to carry out a maintenance operation or the presence of a minor fault.
- Compressors running status : set of outputs (as many as the compressors number) indicating which compressors are running.

TECHNICAL INSIGHTS

Models 451A to 1301A: Inverter-driven Thunderbolt screw compressor 06T

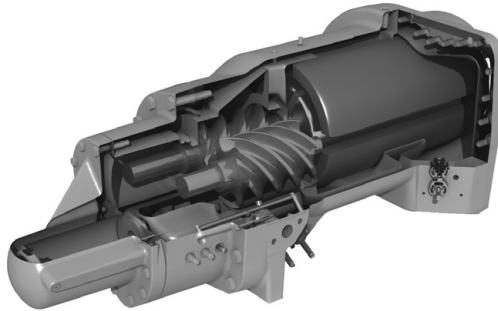

- The Carrier 06T screw compressor designed for operation with R-1234ze(E) refrigerant benefits from Carrier's long experience in the development of twin-rotor screw compressors. The design of the Thunderbolt compressors is based on the successful 06T screw compressor, core of the well-known Aquaforce series.
- Advanced control algorithms combine inverter frequency output with motor input logic to minimise mechanical part stress, resulting in best compression performance and high chiller reliability. The compressor is equipped with bearings with oversized rollers, oil pressure lubricated for reliable and durable operation, even at maximum load.
- Screw compressors use positive displacement principle to compress gases at higher pressure. As a result, in case of exceptional high temperature condenser side (due for example to water-pipes fouling or operation in harsh climate with an external dry cooler) the compressor does not switch off, but continues operation at reduced capacity (unloaded mode).
- The silencer in the discharge line considerably reduces discharge gas pulsations for much quieter operation.
- The condenser includes an oil separator that minimises the amount of oil in circulation in the refrigerant circuit and re-directs it to the compressor function.

TECHNICAL INSIGHTS

Models 1401A & 1601A: New generation of Carrier 06Y variable-speed twin screw compressor

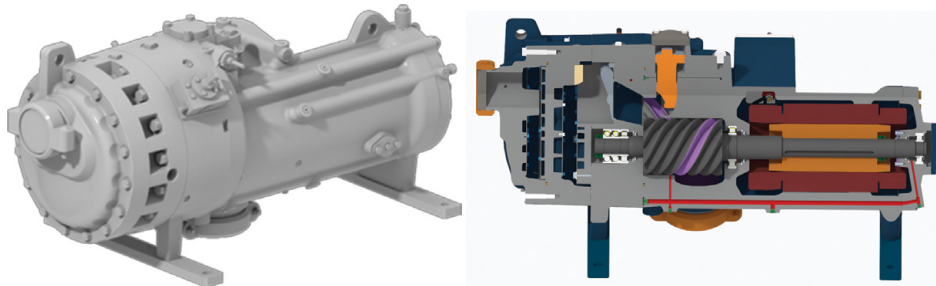

The new generation of 06Y variable-speed twin screw compressors benefits from Carrier's long experience in the development of twin-rotor screw compressors. The 06Y compressor design is based on the successful 06T screw compressor, core of the well-known AquaForce series with a number of modifications to reduce noise level and improve the energy efficiency especially during part-load operation.

This new technology enables the compressor to achieve a Cos Phi of 0.98. Cos Phi close to 1 means that there is no energy lost in the distribution system thus, guaranteeing low power costs granted by electrical utilities, low energy costs and higher PUE of data centers.

- New 06Y twin screw compressor optimized for variable speed operation: Elimination of the slide valve, built-in volume index control (Vi) valve for both optimal full and part-load performance, high efficiency AC motor with stepless inverter control from 20% to 100%.
- Separate air-cooled inverter drive for increased reliability
- New 06Y twin screw compressor design with Integrated Resonator Array (IRA) to reduce the sound level by up to 6 dB(A) when compared with previous 06T generation
- Integrated Check Valve for quiet shutdown
- Bearing life exceeding 100 000 hours.
- A dedicated oil separator is integrated to the condenser to ensure maximum oil return: Oil separates from refrigerant by gravity and returns to the low pressure side of the compressor without use of additional pumps.
- Volume index control (Vi) valve provides a reliable method of adjusting the compression ratio to better match system demand. It provides optimal performance regardless of operating condition
- Screw compressors work on the positive displacement principle to compress gas to a higher pressure. As a result, if there is an unusually high pressure in the condenser (due for example to coil fouling or operation in harsh climate) the compressor does not switch off, but continues operation at reduced capacity (unloaded mode).
- Compressor is installed on a decoupling structure to minimize the vibration emission for much quieter operation.

Digit number

1	2	3	4	5	6	7	8	9	10	11	12	13	14	15	16	17	18
3	0	X	W	-	V	Z	E	0	3	0	1	A	0	0	0	1	-

Legend :

- Digit 1 to 4 : Water-cooled chiller with screw compressor
- Digit 5 : Application type, - = Cooling, H = Heating
- Digit 6 : Efficiency, V = Variable
- Digit 7 & 8 : Unit using R-1234ze(E) refrigerant
- Digit 9 to 12 : Model number based on cooling capacity in kW
- Digit 13 : Index for major product modification (visible impact for customer)
- Digit 14 to 17 : Counter used to generate a one time product code
- Digit 18 : Not used

30XWV(H)ZE – TECHNICAL INSIGHTS MODELS 451A TO 1301A

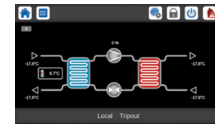

CARRIER TWIN ROTOR SCREW COMPRESSOR WITH AC MOTOR

Performance & efficiency

- Exclusive Carrier design
- Variable-speed twin rotor screw compressor
- Sliding valve & variable-speed control (30%-100%)
- Air-cooled inverter drive for increased reliability
- Bearing life exceeding 100 000 hours
- 99.7% of units without a compressor failure

ADVANCED SMARTVU™ 7-INCH COLOUR TOUCH SCREEN INTERFACE

- Exclusive Carrier design
- 10 languages available including DE, EN, ES, FR, IT, NL, PT, TR + one additional customer choice
- Touch screen user interface
- BACnet, J-Bus or LON communication interfaces
- Optional wireless connectivity
- Web server capabilities-easy remote access via internet
- Trending capabilities



FLOODED SHELL & TUBE HEAT EXCHANGER

- Exclusive Carrier design
- Tube submersed in refrigerant (more efficient)
- New tubes with micro grooves
- Maximum heat transfer
- Optimized water pressure drop
- Lower pumping cost



OPTIMIZED FOR ULTRA-LOW GWP PURETEC™ (R-1234ze(E)) AND A1-RATED R-515B REFRIGERANTS

- HFO R-1234ze(E) with Global Warming Potential (GWP) below 2.
- Long-term solution to meet the F-Gas regulation.

30XWV(H)ZE – TECHNICAL INSIGHTS MODELS 1401A & 1601A



LATEST GENERATION CARRIER TWIN ROTOR SCREW COMPRESSOR WITH AC MOTOR

Performance & efficiency

- Exclusive Carrier design
- Variable-speed twin rotor screw compressor
- Vi piston for optimized performances in all operating conditions
- Liquid motor cooling for a wide operating envelope (up to 60 °C)
- Stepless variable-speed control allowing low part load (20%-100%)
- Bearing life exceeding 100 000 hours

Quiet operation

- Integrated resonator array for compressor acoustic attenuation
- Air-cooled inverter drive for increased reliability
- Compressor installed on decoupling structure to minimize the vibrations



ADVANCED SMARTVU™ 7-INCH COLOUR TOUCH SCREEN INTERFACE

- Exclusive Carrier design
- 10 languages available including DE, EN, ES, FR, IT, NL, PT, TR + one additional customer choice
- Touch screen user interface
- BACnet, J-Bus or LON communication interfaces
- Optional wireless connectivity
- Web server capabilities-easy remote access via internet
- Trending capabilities



FLOODED SHELL & TUBE HEAT EXCHANGER

- Exclusive Carrier design
- Tube submersed in refrigerant (more efficient)
- New tubes with micro grooves
- Maximum heat transfer
- Optimized water pressure drop
- Lower pumping cost

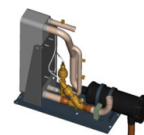

EXPANSION VALVE & ECONOMIZER

A single subassembly that offers:

- Refrigerant control accuracy
- Increased unit cooling capacity
- Higher efficiencies



OPTIMIZED FOR ULTRA-LOW GWP PURETEC™ (R-1234ze(E)) AND A1-RATED R-515B REFRIGERANTS

- HFO R-1234ze(E) with Global Warming Potential (GWP) below 2.
- Long-term solution to meet the F-Gas regulation.

OPTIONS

Options	N°	Description	Advantages	Use for 30XW-(H)VZE range
Light-brine solution, down to -3 °C	8	Implementation of new algorithms of control to allow chilled brine solution production down to -3 °C when ethylene glycol is used (0 °C with propylene glycol)	Matches with most application requirements for ground-sourced heat pumps and fits with many industrial processes requirements	451A-1601A (see dedicated paragraph)
Control Box: increase IP protection IP44	20	Control box thightness reinforced. Electrical box enclosure and outside electrical component following IEC 60529 standard	Protects the inside of the electrical box from dust, water and sand. In general this option is recommended for installations in polluted environments	1401A-1601A
Lead/Lag operation	58	Unit equipped with supplementary water outlet temperature sensor kit to be field-installed allowing Lead/Lag operation of two units connected in parallel	Optimised operation of two units connected in parrallele operation with operating time equalisation	451A-1601A
Condenser insulation	86	Thermal condenser insulation	Minimizes thermal dispersions condenser side (key option for heat pump or heat recovery applications) and allows compliancy with special installation criteria (hot parts insulated)	451A-1601A
Service valve set	92	Liquid line valve (evaporator inlet) and compressor suction line valve	Allow isolation of various refrigerant circuit components for simplified service and maintenance	451A-1301A
Discharge Isolation Valve	93A	Discharge line valve (oil separator inlet)	Allow isolation of various refrigerant circuit components for simplified service and maintenance	1401A-1601A
Evaporator with one pass less	100C	Evaporator with one pass on the water side. Evaporator inlet and outlet on opposite sides.	Easy to install, depending on site. Reduced pressure drops	451A-1601A
Condenser with one pass less	102C	Condenser with one pass on the water side. Condenser inlet and outlet on opposite sides.	Easy to install, depending on site. Reduced pressure drops	451A-1601A
21 bar evaporator	104	Reinforced evaporator for extension of the maximum water-side service pressure to 21 bar (standard 10 bar)	Covers applications with a high water column evaporator side (typically high buildings)	451A-1301A
21 bar condenser	104A	Reinforced condenser for extension of the maximum water-side service pressure to 21 bar (standard 10 bar)	Covers applications with a high water column condenser side (typically high buildings)	451A-1301A
Reversed evaporator water connections	107	Evaporator with reversed water inlet/outlet	Easy installation on sites with specific requirements	451A-1601A
Reversed condenser water connections	107A	Condenser with reversed water inlet/outlet	Easy installation on sites with specific requirements	451A-1601A
Lon gateway	148D	Two-directional communication board complying with Lon Talk protocol	Connects the unit by communication bus to a building management system	451A-1601A
Bacnet over IP	149	Two-directional high-speed communication using BACnet protocol over Ethernet network (IP)	Easy and high-speed connection by ethernet line to a building management system. Allows access to multiple unit parameters	451A-1601A
Modbus over IP and RS485	149B	Bi-directional high-speed communication using Modbus protocol over Ethernet network (IP)	Easy and high-speed connection by ethernet line to a building management system. Allows access to multiple unit parameters	451A-1601A
High Condensing temperature (up to 60 °C LWT)	150	VFD optimized for operation at high condensing temperature	Increased condenser leaving water temperature up to 60 °C. Allows applications with high condensing temperature (heat pumps, installations with not generously sized dry coolers or more generally, installations with dry coolers in hot climate)	1401A-1601A
Condensing temperature limitation	150B	Limitation of the maximum condenser leaving water temperature to 45 °C	Reduced maximum power input and current absorption: power cables and protection elements can therefore be downsized	451A-1301A

OPTIONS

Options	N°	Description	Advantages	Use for 30XW-(H)VZE range
Control for low cond. temperature systems	152	Output signal (0-10 V) to control the condenser water inlet valve	Simple installation: for applications with cold water at condenser inlet (ex. ground-source, groundwater-source, superficial water-source applications) the signal permits to control a 2 or 3-way valve to maintain condenser water temperature (and so condensing pressure) at acceptable values	451A-1601A
Dry Cooler Control	154	Adaptation of the control box for communication with the dry cooler via a bus. For dry cooler need to select the cabinet with option control cabinet manage by the chiller control	Easy system management, extended control capabilities of a remote dry cooler	1401A-1601A
Energy Management Module	156	EMM Control board with additional inputs/ outputs. See Energy Management Module option chapter	Extended remote control capabilities (Set-point reset, ice storage end, demand limits, boiler on/off command...)	451A-1601A
Input contact for Refrigerant leak detection	159	0-10 V signal to report any refrigerant leakage in the unit directly on the controller (the leak detector itself must be supplied by the customer)	Immediate customer notification of refrigerant losses to the atmosphere, allowing timely corrective actions	451A-1601A
Dual relief valve on 3-way valve	194	Three-way valve upstream of dual relief valves on the evaporator and the oil separator	Valve replacement and inspection facilitated without refrigerant loss. Comforms to European standard EN378/BGVD4	451A-1601A
Compliance with Swiss regulations	197	Additional tests on the water heat exchangers: supply (additional of PED documents) supplementary certificates and test certifications	Conformance with Swiss regulations	451A-1601A
Compliance with Russian regulations	199	EAC certification	Conformance with Russian regulations	451A-1301A
Compliance with Australian regulations	200	Unit approved to Australian code	Conformance with Australian regulations	451A-1301A
Low noise level	257	Sound insulation on main vibrating components	Reduced sound emissions	451A-1601A
Welded evaporator connection kit	266	Victaulic piping connections with welded joints	Easy installation	451A-1601A
Welded condenser water connection kit	267	Victaulic piping connections with welded joints	Easy installation	451A-1601A
Flanged evaporator water connection kit	268	Victaulic piping connections with flanged joints	Easy installation	451A-1601A
Flanged condenser water connection kit	269	Victaulic piping connections with flanged joints	Easy installation	451A-1601A
Thermal compressor insulation	271	The compressor is covered with a thermal insulation layer	Prevents air humidity to condensate on the compressor surface	451A-1601A
EMC classification C2, as per EN 61800-3	282	Additional RFI filters on the unit power line	Reduces electromagnetic interferences for compliance with emission level category C2 in order to allow the units to operate in the first environment (so called, residential environment)	451A-1601A
Electrical Convenience Outlet	284	230 VAC power supply source provided with plug socket and transformer (180 VA, 0,8 Amps)	Permits connection of a laptop or an electrical device during unit commissioning or servicing	1401A-1601A
Electric energy meter	294	Electricity meter . Display of energy consumption, instantaneous (U, V, I) and cumulated (kWh) on the unit user interface datas available on communication bus	Permits the acquisition, (remote) monitoring of energy used.	1401A-1601A

OPTIONS

Options	N°	Description	Advantages	Use for 30XW-(H)VZE range
Fast Capacity Recovery	295	New software algorithms to allow quick restart and fast loading while preserving unit-reliability	Full capacity recovery in approximately 6 minutes after power failure. Matches requirements of typical critical missions application	451A-1301A
Fast Capacity Recovery	295	New software algorithms to allow quick restart and fast loading while preserving unit-reliability	Full capacity recovery in approximately 3 minutes after power failure. Matches requirements of typical critical missions application	1401A-1601A
BluEdge Digital (Connectivity embedded)	298A	4G modem + antenna system with GPS location to transmit the machine's operating data in real time	Enable BlueEDGE service offer	451A-1601A
Free Cooling Control	313	Control a dry Cooler used for free cooling purpose. This control is a standardized option, IOBoards & control logic are parametric but no product specific logic will be implemented.	Easy system management, Extended control capabilities to a dry cooler used in Free Cooling mode	1401A-1601A
Compliance with Morocco regulation	327	Specifics documents according Morocco regulation	Conformance with Morocco regulations	1401A-1601A
Low GWP A1 R-515B refrigerant	330	Unit delivered with R-515B refrigerant charge (A1, GWP 288)	Reduced CO ₂ footprint (GWP < 300) A1 safety class Reduced installed cost in technical room	451A-1601A

PHYSICAL DATA, 30XW-VZE UNITS

30XW-V ZE / 30XWHVZE			451A	501A	601A	651A	851A	1001A	1101A	1201A	1301A	1401A	1601A		
Heating															
Standard unit Full load performances*	HW1	Nominal capacity	kW	523	581	730	780	1017	1157	1304	1450	1555	1671	1926	
		COP	kW/kW	6,3	6,14	6,04	5,92	6,27	6,29	6,12	5,74	5,61	5,69	5,63	
	HW2	Nominal capacity	kW	491	544	677	730	955	1081	1211	1344	1452	1637	1872	
		COP	kW/kW	4,74	4,6	4,55	4,39	4,73	4,73	4,67	4,42	4,28	4,43	4,43	
	HW3	Nominal capacity	kW	466	508	628	689	906	1007	1122	1242	1367	1635	1860	
		COP	kW/kW	3,52	3,41	3,42	3,24	3,51	3,5	3,52	3,39	3,22	3,45	3,48	
Standard unit Seasonal energy efficiency **	HW1	SCOP _{30/35 °C}	kWh/kWh	7,64	7,39	7,62	7,57	7,45	7,4	7,17	6,64	6,56	6,96	7,03	
		η _{s heat} _{30/35 °C}	%	298	288	297	295	290	288	279	257	254	270	273	
	HW3	SCOP _{47/55 °C}	kWh/kWh	5,34	5,3	5,26	5,21	5,31	5,39	5,46	5,17	5,11	5,21	5,31	
		η _{s heat} _{47/55 °C}	%	206	204	202	201	204	207	210	199	197	200	204	
			P _{rated}	kW	559	614	761	827	1086	1217	1361	1507	1645	1936	2208
	Cooling														
Standard unit Full load performances*	CW1	Nominal capacity	kW	448	496	620	660	870	991	1115	1227	1312	1416	1635	
		EER	kW/kW	5,53	5,39	5,26	5,14	5,57	5,6	5,47	5,14	5,05	5,00	5,01	
	CW2	Nominal capacity	kW	670	728	915	970	1301	1455	1296	1423	1521	1897	2216	
		EER	kW/kW	7,88	7,49	7,26	7,14	7,9	7,74	6,19	5,76	5,7	6,81	6,91	
Standard unit Seasonal energy efficiency **		SEER _{12/7 °C} Comfort low temp.	kWh/kWh	8,12	8,15	8,77	8,37	8,41	8,48	7,48	7,33	7,13	8,37	8,58	
		η _{s cool} _{12/7 °C}	%	322	323	348	332	333	336	296	290	282	332	340	
		SEPR _{12/7 °C} Process high temp.	kWh/kWh	10,49	10,23	10,42	10,03	10,71	10,71	9,66	9,12	8,25	6,39	6,55	
Integrated Part Load value		IPLV.SI	kW/kW	9,216	8,932	9,459	9,221	9,359	9,406	8,981	8,708	8,548	8,484	8,829	

* In accordance with standard EN14511-3:2022

** In accordance with standard EN14825:2022,

HW1 Heating mode conditions: Evaporator entering/leaving water temperature 10 °C/7 °C, condenser entering/leaving water temperature 30 °C/35 °C, evaporator and condenser fouling factor 0 m². k/W

HW2 Heating mode conditions: Evaporator entering/leaving water temperature 10 °C/7 °C, condenser entering/leaving water temperature 40 °C/45 °C, evaporator and condenser fouling factor 0 m². k/W

HW3 Heating mode conditions: Evaporator entering/leaving water temperature 10 °C/7 °C, condenser entering/leaving water temperature 47 °C/55 °C, evaporator and condenser fouling factor 0 m². k/W

CW1 Cooling mode conditions: Evaporator water entering/leaving temperature 12 °C/7 °C, condenser entering/leaving water temperature 30 °C/35 °C, evaporator and condenser fouling factor 0 m².K/W

CW2 Cooling mode conditions: Evaporator water entering/leaving temperature 23 °C/18 °C, condenser entering/leaving water temperature 30 °C/35 °C, evaporator and condenser fouling factor 0 m².K/W

η_{s heat}_{30/35 °C} & SCOP_{30/35 °C} Values calculated in accordance with EN14825:2022

η_{s heat}_{47/55 °C} & SCOP_{47/55 °C} Values calculated in accordance with EN14825:2022

η_{s cool}_{12/7 °C} & SEER_{12/7 °C} Values calculated in accordance with EN14825:2022

SEPR_{12/7 °C} Values calculated in accordance with EN14825:2022

IPLV.SI In accordance with AHRI standard (Air-conditioning, Heating and Refrigeration Institute, USA) : AHRI 551/591 (SI).

Bold values compliant to Ecodesign regulation: (EU) No 2016/2281 for Comfort application

Bold values compliant to Ecodesign regulation: (EU) No 2016/2281 for Process Application High Temperature

In accordance with AHRI standard (Air-conditioning, Heating and Refrigeration Institute, USA) : AHRI 551/591 (SI).



Eurovent certified values



AHRI certified values
30XW-V ZE only

CARRIER participates in the ECP programme for LCP-HP Check ongoing validity of certificate: www.eurovent-certification.com

PHYSICAL DATA, 30XW-VZE UNITS

30XW-V ZE / 30XWHVZE		451A	501A	601A	651A	851A	1001A	1101A	1201A	1301A	1401A	1601A
Sound levels - standard unit												
Sound power level ⁽¹⁾	dB(A)	103	103	103	103	104	104	104	104	104	102	103
Sound pressure level at 1 m ⁽²⁾	dB(A)	85	85	85	85	85	85	85	85	85	83	83
Sound levels - standard unit + option 257⁽³⁾												
Sound power level ⁽¹⁾	dB(A)	100	100	100	100	101	101	101	101	101	97	98
Sound pressure level at 1 m ⁽²⁾	dB(A)	82	82	82	82	82	82	82	82	82	77	78
Dimensions - standard unit												
Length	mm	3059	3059	3290	3290	4730	4730	4730	4730	4730	4903	5293
Width	mm	1087	1087	1237	1237	1164	1164	1264	1264	1264	1474	1474
Height	mm	1743	1743	1948	1948	1997	1997	2051	2051	2051	2425	2425
Operating weight⁽⁴⁾	kg	3223	3261	4263	4267	7477	7553	7731	7932	7970	8553	9233
Compressors	Semi-hermetic 06T screw compressors, 60 r/s										Semi-hermetic 06Y variable speed screw compressor	
Circuit A	-	1	1	1	1	1	1	1	1	1	1	1
Circuit B	-	-	-	-	-	1	1	1	1	1	1	1
Oil - standard unit												
HATCOL-4496												
Circuit A	l	20	20	25	25	20	20	25	25	25	18	18
Circuit B	l	-	-	-	-	20	20	20	25	25	15	18
Refrigerant - standard unit												
R-1234ze(E) A2L												
Circuit A	kg	130	130	180	175	120	120	115	115	118	193	193
	teq CO ₂	0,2	0,2	0,2	0,2	0,2	0,2	0,2	0,2	0,2	0,3	0,3
Circuit B	kg	-	-	-	-	120	120	120	115	118	177	193
	teq CO ₂	-	-	-	-	0,2	0,2	0,2	0,2	0,2	0,2	0,3
Refrigerant - option 330												
R-515B A1												
Circuit A	kg	132	132	183	178	122	122	117	117	120	196	196
	teq CO ₂	38,0	38,0	52,7	51,3	35,1	35,1	33,7	33,7	34,6	56,4	56,4
Circuit B	kg	-	-	-	-	122	122	122	117	120	180	196
	teq CO ₂	-	-	-	-	35,1	35,1	35,1	33,7	34,6	52	56,4
Capacity control												
Smart Vu™, inverter-driven compressor, electronic expansion valve (EXV)												
Minimum capacity ⁽⁵⁾	%	30	30	15	15	30	30	15	15	15	12	11
Evaporator												
Multi-pipe flooded type												
Water volume	l	106	106	154	154	297	297	297	297	297	388	418
Water connections (Victaulic)	in	6	6	8	8	8	8	8	8	8	8	8
Drain and vent connections (NPT)	in	3/8	3/8	3/8	3/8	3/8	3/8	3/8	3/8	3/8	3/8	3/8
Max. water-side operating pressure	kPa	1000	1000	1000	1000	1000	1000	1000	1000	1000	1000	1000
Condenser												
Multi-pipe flooded type												
Water volume	l	112	112	165	165	340	340	340	340	340	391	461
Water connections (Victaulic)	in	6	6	8	8	8	8	8	8	8	8	8
Drain and vent connections (NPT)	in	3/8	3/8	3/8	3/8	3/8	3/8	3/8	3/8	3/8	3/8	3/8
Max. water-side operating pressure	kPa	1000	1000	1000	1000	1000	1000	1000	1000	1000	1000	1000

- (1) In dB ref=10⁻¹² W, 'A' weighted. Declared dual-number noise emission values in accordance with ISO 4871 with an associated uncertainty of +/-4dB(A). Measured in accordance with ISO 9614-1.
- (2) In dB ref 20µPa, 'A' weighted. Declared dual-number noise emission values in accordance with ISO 4871 with an associated uncertainty of +/-4dB(A). For information, calculated from the sound power Lw(A).
- (3) Options: 257=Low noise level ;
- (4) Including refrigerant , oil and water inside exchanger, Values are guidelines only.
- (5) For standard conditions. Depending on operating conditions, unit might have a different minimum part load or cycle.

ELECTRICAL DATA

30XW-VZE /30XWHVZE		451A	501A	601A	651A	851A	1001A	1101A	1201A	1301A	1401A	1601A
Power circuit												
Nominal power supply	V-ph-Hz	400-3-50										
Voltage range	V	360-440										
Control circuit												
24 V via the built-in transformer												
Start-up current⁽¹⁾	A	Negligible (lower than maximum current drawn)										
Maximum power factor⁽²⁾		0,91-0,93	0,91-0,93	0,91-0,93	0,91-0,93	0,91-0,93	0,91-0,93	0,91-0,93	0,91-0,93	0,91-0,93	0,89-0,92	0,91-0,94
Cosine phi		> 0,98	> 0,98	> 0,98	> 0,98	> 0,98	> 0,98	> 0,98	> 0,98	> 0,98	0,99	0,99
Harmonic distortion rate⁽³⁾	%	35-45	35-45	35-45	35-45	35-45	35-45	35-45	35-45	35-45	40-50	35-45
Power connection point		1	1	1	1	2	2	2	2	2	1	1
Maximum power input⁽⁴⁾												
Circuit A	kW	135	157	189	208	135	157	189	189	208	478	551
Circuit B	kW	-	-	-	-	135	157	157	189	208		
Eurovent current draw⁽⁵⁾												
Circuit A	A	129	148	180	197	129	149	180	180	197	463	525
Circuit B	A	-	-	-	-	129	149	149	180	197		
Maximum current draw (Un)⁽⁴⁾												
Circuit A	A	210	245	295	325	210	245	295	295	325	752	866
Circuit B	A	-	-	-	-	210	245	245	295	325		
Maximum current draw (Un -10%)⁽³⁾												
Circuit A	A	220	260	313	345	220	260	313	313	345	818	915
Circuit B	A	-	-	-	-	220	260	260	313	345		
Maximum power input with option 150B⁽⁴⁾												
Circuit A	kW	114	134	161	177	114	134	161	161	177	-	-
Circuit B	kW	-	-	-	-	114	134	134	161	177	-	-
Maximum current draw (Un) with option 150B⁽⁴⁾												
Circuit A	A	180	213	257	283	180	213	257	257	283	-	-
Circuit B	A	-	-	-	-	180	213	213	257	283	-	-
Dissipated power⁽³⁾	W	3000	4200	4700	5300	6000	8400	8900	9400	10600	14340	16530
Maximum power factor⁽²⁾ with option 150		-	-	-	-	-	-	-	-	-	0,91-0,94	0,91-0,94
Maximum power input⁽⁴⁾ with option 150	kW	-	-	-	-	-	-	-	-	-	564	630
Maximum current draw (Un)⁽⁴⁾ with option 150	A	-	-	-	-	-	-	-	-	-	884	979
Maximum current draw (Un -10%)⁽³⁾ with option 150	A	-	-	-	-	-	-	-	-	-	943	996
Dissipated power⁽³⁾ with option 150	W	-	-	-	-	-	-	-	-	-	16930	18930

(1) Instantaneous start-up current.

(2) Values obtained at operation with maximum unit power input. Values deteriorate when load lowers.

The highest impact on the installation occurs when the current is maximum. Therefore compliance of the installation regarding voltage harmonic distortion shall be usually checked at maximum load conditions.

Vary according to the installation's short circuit ratio

(3) Values obtained at operation with maximum unit power input.

(4) Values obtained at operation with maximum unit power input. Values given on the unit name plate.

(5) Eurovent unit operating conditions: evaporator entering/leaving water temperature = 12 °C/7 °C, condenser entering/leaving water temperature = 30 °C/35 °C.

ELECTRICAL DATA

Electrical Note 30XW-VZE / 30XWHVZE units

Electrical data notes and operating conditions, **30XW-VZE / 30XWHVZE units**

- The unit has one or two connection point. Refer to table Electrical data.
- For 30XW(H)VZE 451A to 1301A : The main supply disconnecting device is not included in the electrical cabinet.
For 30XW(H)VZE 1401A to 1601A : The main supply disconnecting device is included in the electrical cabinet.
- The main short circuit protection is not included in the electrical cabinet. Refer to table Short-circuit stability current.
- Field connections: All connections to the system and the electrical installations must be in full accordance with all applicable codes.
- The unit is designed and built to ensure conformance with local codes ⁽¹⁾. Particularly, the recommendations of European standard EN 60204-1 (corresponds to IEC60204-1) (machine safety - electrical machine components - part 1: general regulations) are specifically taken into account, when designing the electrical equipment⁽²⁾.
- The absence of the main supply disconnecting device is an exception that shall be considered at the building installation level
- The electrical equipment is designed such that it is not a source of ignition for A2L refrigerant during normal and frequent forseeable abnormal operation. Complementary risk reduction for prevention of the formation of explosive atmosphere (detection and ventilation) must be achieved by all necessary measures in the building installation.
- Annex B of EN 60204 1 is intended to define the electrical characteristics that are necessary for good integration of the unit in the installation
Those describes below apply alongside the other information provided in this document:
 1. Operating Environment as classified in IEC60364 ⁽³⁾:
 - Indoor installation
 - Ambient temperature range: +5 °C to +42 °C, class AA5
 - Altitude: lower than or equal to 2000 m (above 1600 m, the maximum temperature must be reduced by 0,5 K for every aditionnal 100 m)
 - Presence of water: class AD2 (possibility of water droplets)
 - Presence of hard solids, class 4S2 (no significant dust present)
 - Presence of corrosive and polluting substances, class 4C2 (negligible)
 2. Power supply frequency variation: ± 2 Hz.
 3. The neutral (N) line must not be connected directly to the unit (if necessary use a transformer).
 4. Overcurrent protection of the power supply conductors is not provided with the unit.

5. The unit is designed for connection to TN systems (IEC 60364). For IT systems the earth connection must not be at the network earth. Provide a local earth, consult competent local organisations to complete the electrical installation.
6. Electromagnetic environment: classification of the electromagnetic environment is described in standard EN 61800-3 (corresponds to IEC 61800-3):
 - Immunity to external interference defined by the second environment ⁽⁴⁾
 - Interference emission as defined in category C3 ⁽⁵⁾
- Due to the harmonic currents, the integrated frequency variator in the unit is a source of interference. An analysis may be required to verify if these interferences exceed the compatibility limits of the other devices connected to the same power supply network. The compatibility levels inside an electrical installation, that must be met at the in-plant coupling point (IPC) to which other loads are connected are described in standard 61000-2-4. Two characteristics are required for this analysis:
 - The short-circuit ratio (Rsce) of the installation calculated at the in-plant coupling point (IPC).
 - The total harmonic current distortion rate (THDI), calculated for the machine at maximum capacity.
- Derived currents: If protection by monitoring the leakage currents is necessary to ensure the safety of the installation, the presence of derived currents introduced by the use of frequency variators in the unit must be considered. In particular the reinforced immunity protection types and a control value not lower than 150 mA are recommended to control differential protection devices.

NOTE: If particular aspects of an actual installation do not conform to the conditions described above, or if there are other conditions which should be considered, always contact your local Carrier representative.

- (1) Generally the recommendations of IEC 60364 are accepted as compliance with the requirements of the installation directives.
- (2) Conformance with EN 60204-1 also enables to meet the requirements of the Machinery Directive.
- (3) The required protection level for this class is IP21B or IPX1B (according to reference document IEC 60529). All 30XW-VZE/30XWHVZE have IP23 units minimum fulfil this protection condition.
- (4) Example of installations of the second environment: industrial zones, technical locations supplied from a dedicated transformer.
- (5) Category C3 is suitable for use in an industrial environment and is not designed for use in a public low-voltage system that supplies residential locations. Category C2 permits this type of installation.

PART LOAD PERFORMANCES

SEER for comfort chillers (in accordance with EU ECODESIGN)

The SEER (Seasonal energy efficiency ratio) permits the evaluation of the average energy efficiency of comfort chillers, based on multiple operating conditions (load variation from 0% to 100%). From 1st January 2021, Tier 2, European member states impose minimum SEER values to meet the requirements of Eco-design directive for ENER Lot 21 comfort cooling chillers. The Ecodesign Directive aims at minimizing the environmental impact of energy-related products under consideration of their full lifecycle.

EU ECODESIGN MEPS ⁽¹⁾ for water-cooled chillers		Tier 2 (from 01/01/2021)
SEER for comfort chiller < 400 kW	kWh/kWh	5,08
SEER for comfort chiller from 400 to 1500 kW	kWh/kWh	6,38
SEER for comfort chiller from 1500 to 2000 kW	kWh/kWh	6,88



SEER is : the new metric for chillers in comfort cooling applications.

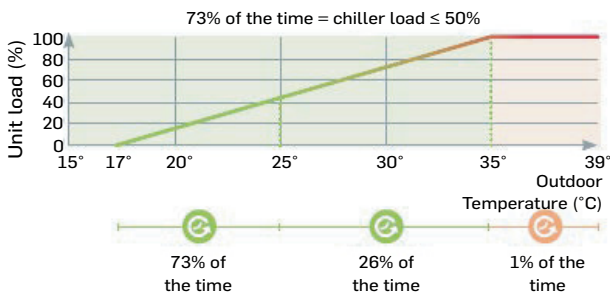

SEPR for process chillers (in accordance with EU ECODESIGN)

The SEPR (Seasonal energy performance ratio) permits the evaluation of the average energy efficiency of process chillers, based on multiple operating conditions (load variation from 80% to 100%). From 1st January 2021, Tier 2, European member states impose minimum SEPR values for process chillers to meet the requirements of Eco-design directive for ENER Lot 21 for high temperature process chillers (2 °C to 12 °C) and from 1st July 2018, for ENER Lot 1 for low temperature process chillers (=< -25 °C) and medium temperature process chillers (-24 °C to -8 °C). The Ecodesign Directive aims at minimizing the environmental impact of energy-related products under consideration of their full lifecycle. All process chillers marked with a CE label must meet the determined SEPR (Seasonal Energy Performance Ratio) value stipulated in EU Directive.



SEPR is the new metric for chillers in industrial process cooling applications.

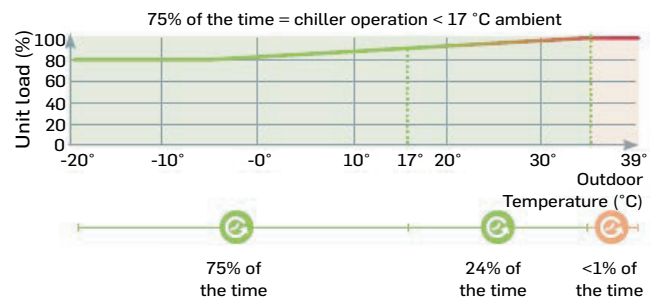

EU ECODESIGN MEPS ⁽¹⁾ for water-cooled chillers		Tier 2 (from 01/07/2018)
SEPR for medium temperature chiller < 300 kW	kWh/kWh	3,29
SEPR for medium temperature chiller > 300 kW	kWh/kWh	4,37

EU ECODESIGN MEPS ⁽¹⁾ for water-cooled chillers		Tier 2 (from 01/01/2021)
SEPR for high temperature chiller < 400 kW	kWh/kWh	7,00
SEPR for high temperature chiller from 400 to 1500 kW	kWh/kWh	8,00
SEPR for high temperature chiller from 1500 to 2000 kW	kWh/kWh	8,50

(1) Minimum Efficiency Performance Standards set by EU member states to comply with EU Ecodesign directive.

SOUND SPECTRUM

30XW-VZE/30XWHVZE 451A - 651A standard units

%		Octave bands, Hz						Sound power levels	
		125	250	500	1k	2k	4k		
100	dB	86	100	103	98	92	82	dB(A)	103
75⁽¹⁾	dB	88	98	99	97	93	83	dB(A)	101
50⁽¹⁾	dB	89	93	92	92	85	84	dB(A)	95
25⁽¹⁾	dB	89	93	92	92	85	84	dB(A)	95

30XW-VZE/30XWHVZE 851A-1301A standard units

%		Octave bands, Hz						Sound power levels	
		125	250	500	1k	2k	4k		
100	dB	73	92	99	101	97	83	dB(A)	104
75⁽¹⁾	dB	64	86	99	100	92	80	dB(A)	103
50⁽¹⁾	dB	79	80	92	91	81	79	dB(A)	95
25⁽¹⁾	dB	98	88	94	89	77	78	dB(A)	94

30XW-VZE/30XWHVZE 1401A standard unit

%		Octave bands, Hz						Sound power levels	
		125	250	500	1k	2k	4k		
100	dB	89	89	85	93	98	96	dB(A)	102
75⁽¹⁾	dB	85	91	96	91	93	90	dB(A)	99
50⁽¹⁾	dB	86	88	89	88	85	82	dB(A)	93
25⁽¹⁾	dB	85	92	86	83	85	78	dB(A)	90

30XW-VZE/30XWHVZE 1601A standard unit

%		Octave bands, Hz						Sound power levels	
		125	250	500	1k	2k	4k		
100	dB	90	87	85	100	96	95	dB(A)	103
75⁽¹⁾	dB	84	83	92	96	94	91	dB(A)	101
50⁽¹⁾	dB	81	83	95	97	90	84	dB(A)	99
25⁽¹⁾	dB	81	93	89	85	87	76	dB(A)	92

30XW-VZE/30XWHVZE 451A - 651A - units with option 257⁽²⁾

%		Octave bands, Hz						Sound power levels	
		125	250	500	1k	2k	4k		
100	dB	83	97	100	95	89	79	dB(A)	100
75⁽¹⁾	dB	83	92	96	95	90	79	dB(A)	98
50⁽¹⁾	dB	86	90	89	89	82	81	dB(A)	92
25⁽¹⁾	dB	86	90	89	89	82	81	dB(A)	92

30XW-VZE/30XWHVZE 851A-1301A - units with option 257⁽²⁾

%		Octave bands, Hz						Sound power levels	
		125	250	500	1k	2k	4k		
100	dB	86	97	99	98	92	79	dB(A)	101
75⁽¹⁾	dB	76	91	100	97	88	75	dB(A)	100
50⁽¹⁾	dB	92	86	93	88	76	75	dB(A)	92
25⁽¹⁾	dB	95	85	91	86	74	75	dB(A)	91

30XW-VZE/30XWHVZE 1401A - units with option 257⁽³⁾

%		Octave bands, Hz						Sound power levels	
		125	250	500	1k	2k	4k		
100	dB	86	90	84	93	89	90	dB(A)	97
75⁽¹⁾	dB	83	90	90	86	86	84	dB(A)	93
50⁽¹⁾	dB	82	86	95	93	85	78	dB(A)	96
25⁽¹⁾	dB	83	88	82	78	74	77	dB(A)	85

30XW-VZE/30XWHVZE 1601A - units with option 257⁽³⁾

%		Octave bands, Hz						Sound power levels	
		125	250	500	1k	2k	4k		
100	dB	86	86	85	95	90	88	dB(A)	98
75⁽¹⁾	dB	82	81	89	87	83	82	dB(A)	93
50⁽¹⁾	dB	77	79	92	93	88	80	dB(A)	96
25⁽¹⁾	dB	83	88	83	78	77	71	dB(A)	85

- (1) Values for information only and not contractually binding.
 (2) Evaporator equipped with acoustic insulation.
 (3) Exchanger and discharge pipe equipped with acoustic insulation.

OPERATING LIMITS AND OPERATING RANGE

Models 451A to 1301A

30XW-VZE/30XWHVZE 451A-1301A	Minimum	Maximum
Evaporator		
Entering temperature at start-up	-	35 °C
Leaving temperature during operation	3,3 °C ⁽¹⁾ -3 °C (Option 8)	20 °C
Entering/leaving temperature difference at full load	2,8 K	11,1 K
Condenser		
Entering temperature at start-up	13 °C ⁽²⁾	-
Leaving temperature during operation	19 °C ⁽²⁾	55 °C
Entering/leaving temperature difference at full load	2,8 K	11,1 K

- (1) For low-temperature applications, where the leaving water temperature is below 3,3 °C, a frost protection solution must be used. Please refer to option 8
- (2) For lower condenser temperatures a water flow control valve must be used at the condenser (two or three-way valve) and the use of a variable speed pump is strongly recommended. Please refer to option 152 to ensure the correct condensing temperature.

Notes:

Ambient temperatures: These units are dedicated for indoor environment. The external temperature at chiller start up should be at least 5 °C. For such low ambient, option 152 is recommended. During storage and transport of the 30XW-VZE/30XWHVZE units (including by container) the minimum and maximum permissible temperatures are -20 °C and 72 °C.

Models 1401A & 1601A

30XW-VZE/30XWHVZE 1401A-1601A	Minimum	Maximum
Evaporator		
Entering temperature at start-up °C	-	35 °C
Leaving temperature during operation °C	3 °C ⁽¹⁾ (STD) -3 °C (opt 8)	25 °C
Entering/leaving temperature difference at full load K	2,8 K	11,1 K
Condenser		
Entering temperature at start-up °C	13 °C ⁽²⁾	-
Leaving temperature during operation °C	15 °C ⁽²⁾	50 °C ⁽³⁾ (STD) 60 °C (opt 150) ⁽⁴⁾
Entering/leaving temperature difference at full load K	2,8 K	11,1 K

- (1) For low-temperature applications, where the leaving water temperature is below 3 °C, a frost protection solution must be used. Please refer to option 8
- (2) For lower condenser temperatures a water flow control valve must be used at the condenser (two or three-way valve) and the use of a variable speed pump is strongly recommended. Please refer to option 152 to ensure the correct condensing temperature.
- (3) For high condensing temperature applications (up to 60 °C), Please refer to option 150
- (4) For highest temperatures, some capacity limitation may occur in case of voltage lower than 400 V

Notes:

Ambient temperatures: These units are dedicated for indoor environment. The external temperature at chiller start up should be at least 5 °C. For such low ambient, option 152 is recommended. During storage and transport of the 30XWV(H)ZE 1401A-1601A units (including by container) the minimum and maximum permissible temperatures are -20 °C and 72 °C.

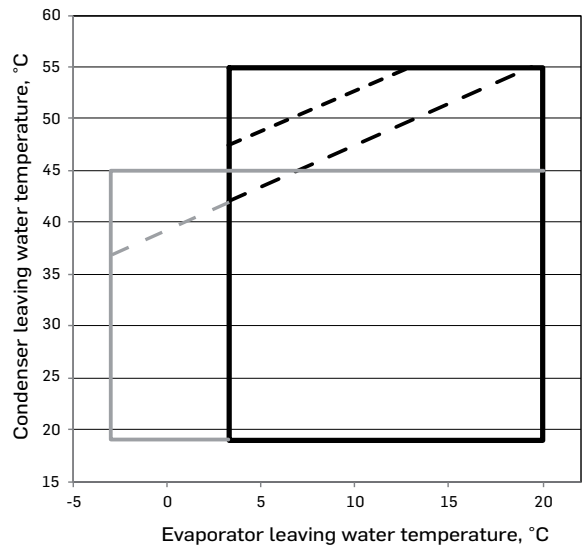

- From approx. 50% to full load
- - - Part load limit approx. 50%
- Minimum load limit
- Option 8 - Light Brine

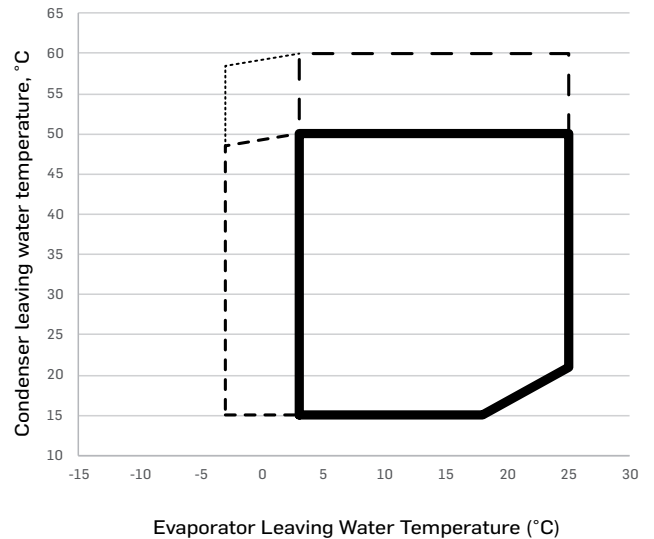

- 30XWVZE ≥ 1400 STD
- - - 30XWVZE ≥ 1400 Option 150
- 30XWVZE ≥ 1400 Option 8 - Light Brine
- Option 8 - Light Brine + Option 150

PRESSURE DROP CURVES, 30XW-VZE/30XWHVZE UNITS

Units with two evaporator passes (standard)

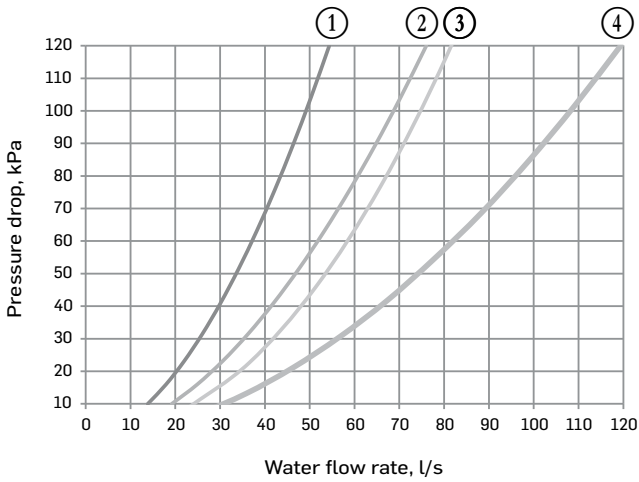

Units with one evaporator pass (option 100C)

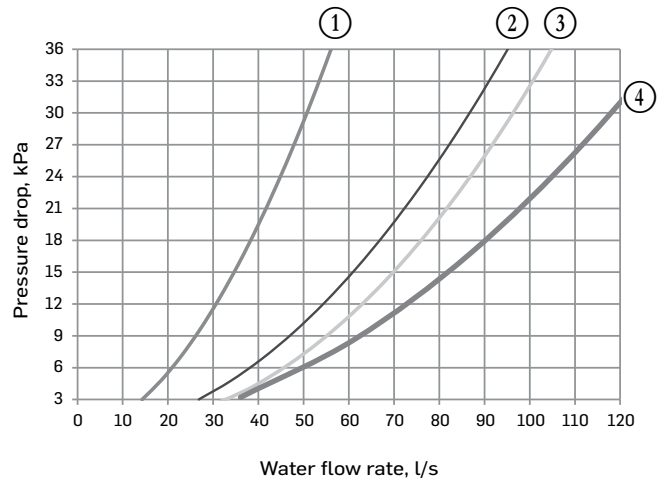

Units with two condenser passes (standard)

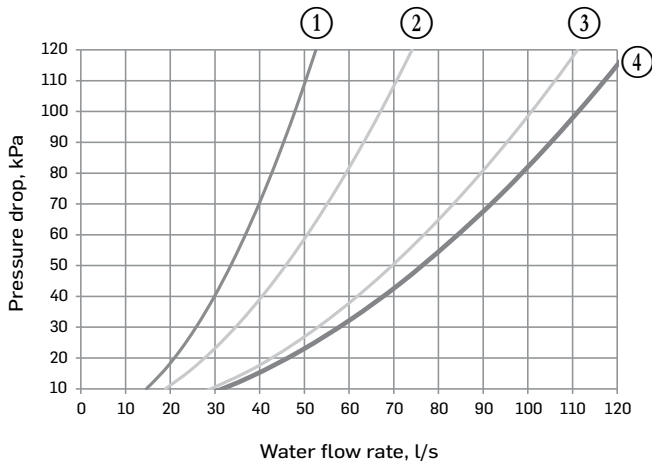

Units with one condenser pass (option 102C)

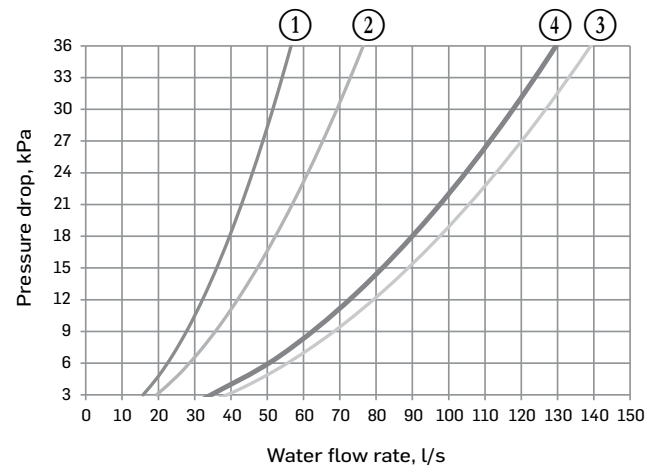

- ① 451A, 501A
- ② 601A, 651A
- ③ 851A, 1001A, 1101A, 1201A, 1301A
- ④ 1401A, 1601A

DIMENSIONS/CLEARANCES

30XW-VZE/30XWHVZE 451A-651A

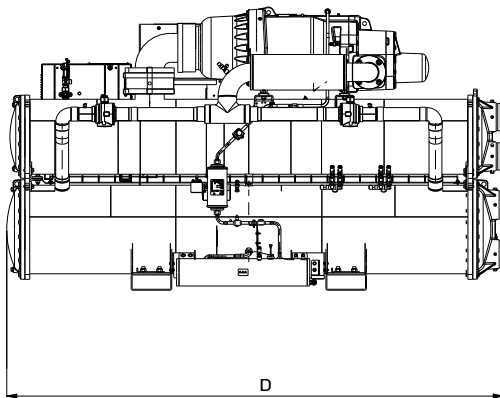
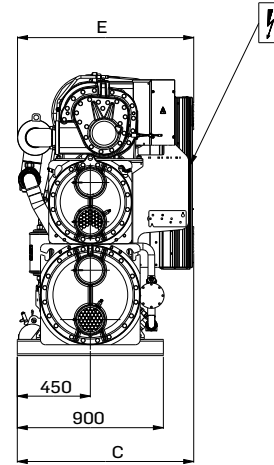
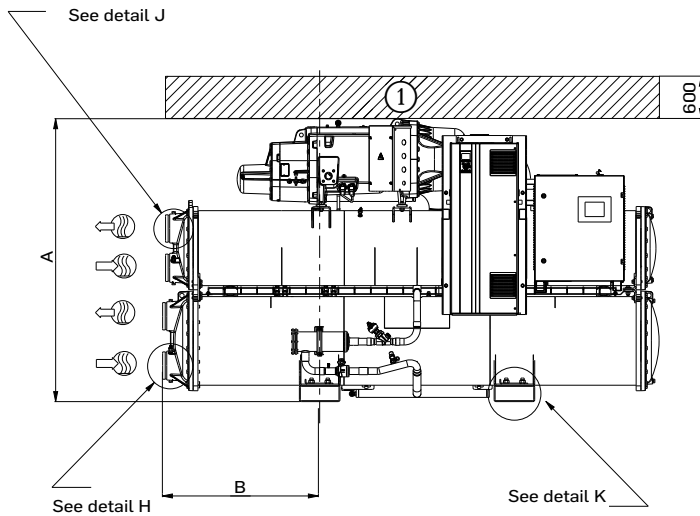

Dimensions in mm								
	A	B	C	D	E	F	G	H
30XW-VZE/30XWHVZE								
451A	1743	968	1087	3059	1086	168,3	168,3	2800
501A	1743	968	1087	3059	1086	168,3	168,3	2800
601A	1948	1083	1137	3290	1237	219,1	219,1	3100
651A	1948	1083	1137	3290	1237	219,1	219,1	3100

Legend

All dimensions are given in mm

① → Services clearances required

② → Space required to remove

Inlet water

Outlet water

Electrical supply entry

NOTES:

Drawings are not contractually binding. Before designing an installation, consult the certified dimensional drawings supplied with the unit or available on request.

For the positioning of the fixing points, weight distribution and centre of gravity coordinates please refer to the dimensional drawings.

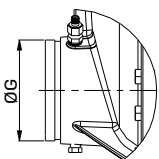
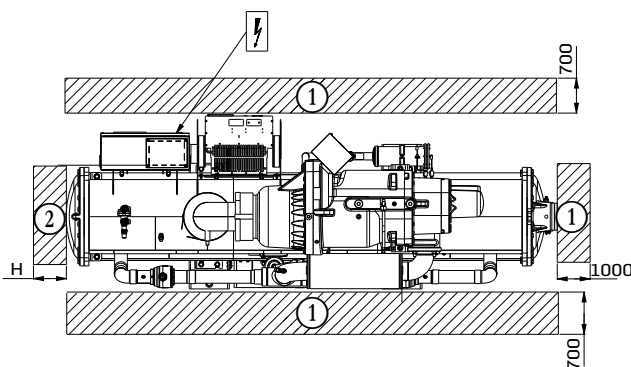

Detail H

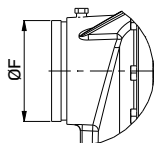

Detail J

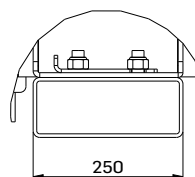

Detail K

DIMENSIONS/CLEARANCES

30XW-VZE/30XWHVZE 851A-1301A

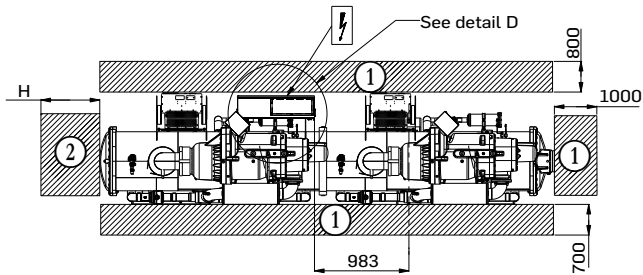
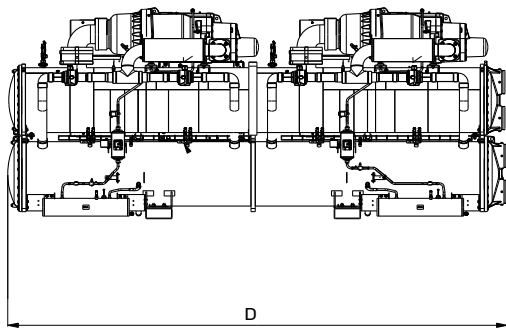
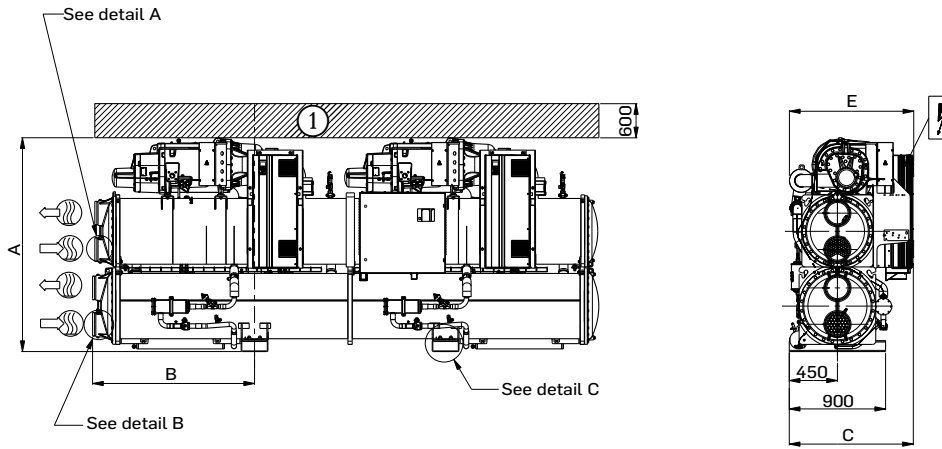

Dimensions in mm								
	A	B	C	D	E	F	G	H
30XW-VZE/30XWHVZE								
851A	1998	1514	1164	4730	1162	219,1	219,1	4500
1001A	1998	1514	1164	4730	1162	219,1	219,1	4500
1101A	2051	1514	1164	4730	1264	219,1	219,1	4500
1201A	2051	1514	1164	4730	1264	219,1	219,1	4500
1301A	2051	1514	1164	4730	1264	219,1	219,1	4500

Legend

All dimensions are given in mm

① → Services clearances required

② → Space required to remove

⊕ → Inlet water

⊖ → Outlet water

⚡ → Electrical supply entry

NOTES:

Drawings are not contractually binding. Before designing an installation, consult the certified dimensional drawings supplied with the unit or available on request.

For the positioning of the fixing points, weight distribution and centre of gravity coordinates please refer to the dimensional drawings.

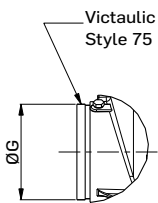

Detail A

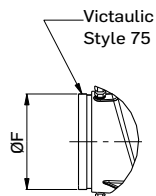

Detail B

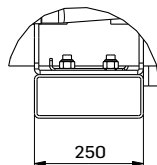

Detail C

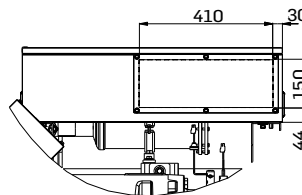

Detail D

DIMENSIONS/CLEARANCES

30XW-VZE/30XWHVZE 1401A - 1601A

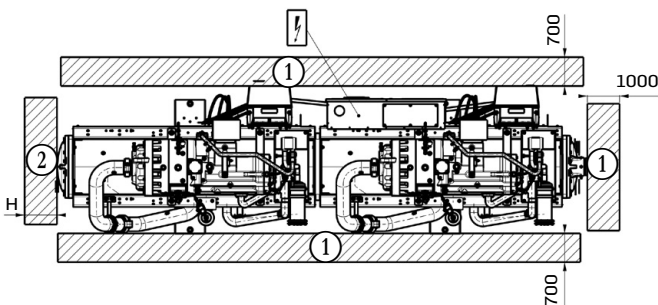
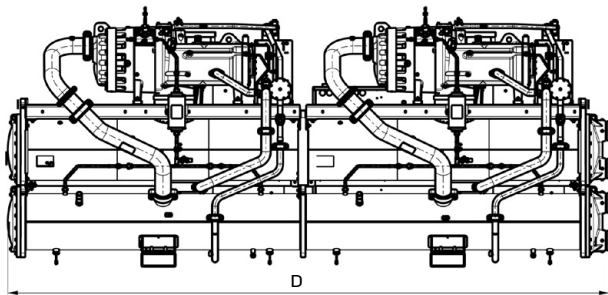
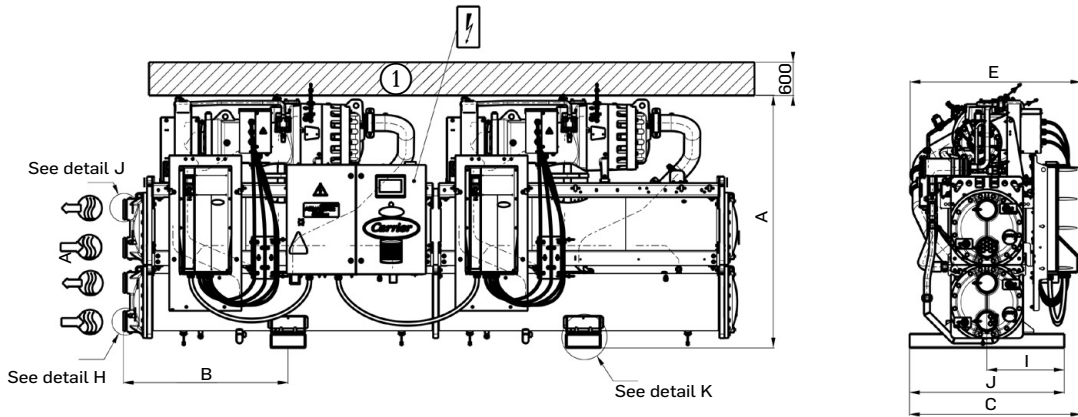

Dimensions in mm										
	A	B	C	D	E	F	G	H	I	J
30XW-VZE/30XWHVZE										
1401A	2425	1444	1461	4904	1474	219	219	4600	650	1300
1601A	2425	1638,5	1461	5293	1474	219	219	5000	650	1300

Legend

All dimensions are given in mm

- ① → Services clearances required
- ② → Space required to remove
- Inlet water
- Outlet water
- Electrical supply entry

NOTES:

Drawings are not contractually binding. Before designing an installation, consult the certified dimensional drawings supplied with the unit or available on request.

For the positioning of the fixing points, weight distribution and centre of gravity coordinates please refer to the dimensional drawings.

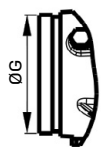

DETAIL H

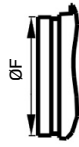

DETAIL J

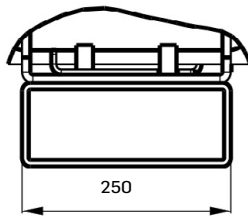

DETAIL K



The quality management system of this product's assembly site has been certified in accordance with the requirements of the ISO 9001 standard (latest current version) after an assessment conducted by an authorized independent third party.

The environmental management system of this product's assembly site has been certified in accordance with the requirements of the ISO 14001 standard (latest current version) after an assessment conducted by an authorized independent third party.

The occupational health and safety management system of this product's assembly site has been certified in accordance with the requirements of the ISO 45001 standard (latest current version) after an assessment conducted by an authorized independent third party.

Please contact your sales representative for more information

Order No.: 10135, 10.2024. Supersedes order No.: 10135, 09.2023.

Carrier, Montluel, France.

Manufacturer reserves the right to change any product specifications without notice.

The illustrations in this document are for illustrative purposes only and not part of any offer for sale or contract. The manufacturer reserves the right to change the design at any time without notice.