



United Technologies
turn to the experts

ALL IN ONE



We make the world a better place to live. We create comfortable, efficient, healthy, safe and secure environments, and ensure the global food supply is transported and preserved for safe consumption.



greenspeed
AQUAEDGE
PUREtec

19DV centrifugal chiller with
PUREtec™ refrigerant and
Greenspeed™ intelligence



United Technologies
turn to the experts



All in one

All in one machine integrates a new generation of innovative technologies including ceramic bearings system, EquiDrive™ compressor and falling film evaporator with low GWP PUREtec™ R-1233zd(E) refrigerant and SmartView™ control.

All in one building identifies 19DV as the ideal solution for extremely reliable and economical operation, quieter performance, smarter controls, flexible installation as well as sustainable development.

All in one city expresses 19DV as chillers that improve the buildings where we live and work, like high-end office buildings and hotels, hospitals, data centers, and industrial premises.

All in one MACHINE

7.0
COP_R

11.8
IPLV_{IP}

30s
swift restart

10%
low load

THD_≤5%
harmonic filter

The AquaEdge™ 19DV centrifugal chiller integrates Carrier's latest technologies:

EquiDrive™ two-stage compressor with simplified and balanced structure enables a more efficient, reliable and quieter machine performance within broader operation range.

Ceramic bearings allow refrigerant lubrication for peace of mind and higher efficiency.

Pioneering falling film design for the evaporator performs in low pressure systems, leading to higher efficiency and less refrigerant charge.

SmartView™ control makes every single operation more efficient and smarter through extended functionality and better remote connectivity.

The use of **PUREtec™ R-1233zd(E)** with low Global Warming Potential GWP~1 fulfills Carrier's commitment to environmental leadership.

Carrier has a rigorous process for defining and testing every component during new product development to ensure reliability and high performance.



AQUAEDGE greenspeed
PUREtec



All in one BUILDING

Equipped with a new generation innovative technologies, AquaEdge™ 19DV centrifugal chillers boost your building's performance.



Reliable



Efficient



Smart



Flexible



Quiet



Sustainable

The AquaEdge™ 19DV addresses all the challenges you may encounter in your building with regard to chillers.



Do you find yourself faced with the following issues related to your building's chillers?

When you **expect a reassuring chiller operation**, but are anxious with failures due to oil lubrication system, the refrigerant leakage from an open motor, the possible loss caused by unexpected power failure.

When you **need more performance from less energy use**, but always receive expensive electricity bills and have limited budget for operating your business and improving customer service.

When you want to **manage everything at your fingertips**, but are forced to operate the chiller in the unventilated basement and annoyed by inadequate historic chiller data to support the business case for a system upgrade.

When you want to **optimize your available floor space**, but struggle in compromising space for your business to allow for the chiller installation including getting it through the door.

When you want to **work in a quieter environment**, but can't concentrate and have to speak loudly with your workmates beside the screaming chillers.

When you want to **be part of a greener world**, but are still looking for a right chiller with higher sustainability to get adequate credits for LEED certification.

Robust and Optimized Chiller Operation

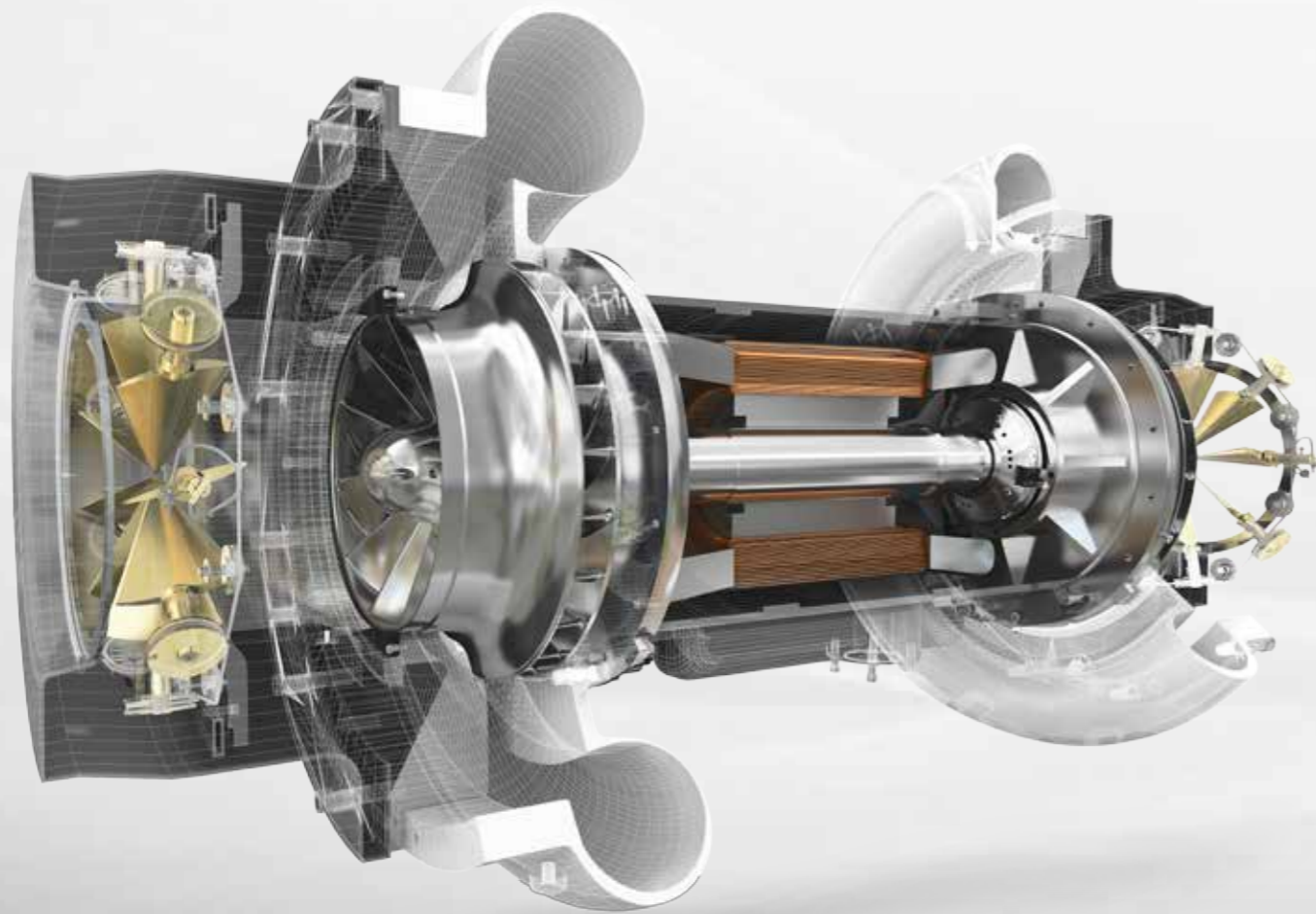

10%
low load

EquiDrive™ compressor

The advanced back-to-back two-stage compressor design naturally balances both radial and axial thrusts on a single shaft and features a simplified system with 30% less hardware, reducing mechanical losses. Dual IGVs and precise VFD control ensure stable operation at all times, even down to 10% part load. This multipoint control delivers a broad operating envelope while maintaining the highest level of efficiency in the harshest conditions.

Refrigerant
lubrication

Ceramic bearing system

The refrigerant lubrication for the ceramic bearing system deals with oil related failures and cuts down maintenance expense. Cutting-edge manufacturing technologies ensure that ceramic bearings are the ideal solution for this kind of lubrication, which includes high-nitrogen steel with excellent toughness, a ceramic rolling element with smooth surface and a glass fiber reinforced PEEK cage. The simple structure with less hardware means more reliable operation at all times.

25
years' life

Hermetic structure design

Designed for 25 years of effective operation, the Carrier semi-hermetic compressor and refrigerant cooled hermetic motor eliminates the risk of refrigerant leakage from the shaft seals and prevents the potential failures caused by coupling design. It also avoids the cost of replacing such consumable parts.

30s
swift restart

30s swift restart

With intelligent SmartView™ control, the 19DV is able to restart the compressor within just 30 seconds (with UPS) after the power recovers and to finish cooling capacity recovery more rapidly to enhance the system reliability and emergency response ability, which especially benefits the data center.

Expect More from Less



7.0
COP_R
full load

High efficiency compressor design

The EquiDrive™ compressor improves the full load efficiency up to 7.0 COP_R under AHRI conditions by optimizing the aero parts with proprietary technologies and reducing 75% of the mechanical transmission loss by removing the gears. The economizer simultaneously increases the refrigeration effect and capacity which results in efficiency even when highly loaded. Beside the optimized IGV also benefit the part load efficiency.

11.8
IPLV_{IP}
part load

Greenspeed™ inverter technology

Carrier Greenspeed™ inverter technology gives a moment-to-moment control to the compressor speed that matches the changing building load with precision and ensures that the chiller is always operating with optimal efficiency at either full or part load. Therefore, the 19DV chiller achieves the part load efficiency of up to 11.8 IPLV_{IP} under AHRI conditions, which cuts operating costs.

+15%
evaporator
efficiency

Falling film evaporator

The Carrier pioneer falling film evaporator designed for low pressure refrigerant increases a heat transferring efficiency by 15% by mitigating the submergence effect in flooded type. The 3D hatched tubing also reduces the heat transfer resistance optimally. The efficiency deterioration caused by oil also disappeared.

+5%
system
efficiency

Refrigerant with excellent efficiency

19DV chillers are specially designed for low GWP PUREtec™ R-1233zd(E) that achieves very high refrigerating cycle efficiency up to 5% higher than a R-134a system due to its outstanding thermodynamic properties.

Everything at your Fingertips



10.4"
touch
screen

10
display
languages

3
BAS
protocols

Cloud
storage

User-friendly interface

Equipped with a 10.4" high resolution colored touch screen, the 19DV chillers are able to deliver comprehensible information in a very efficient and secure manner for the smooth running of daily activities and periodic maintenance. This is possible due to the intuitive menu, animated component level interface with timely running data, graphic trending, auto pushed alarm mail, smart password and more than 10 language choices.



Remote connectivity

The multiple access methods for remote control present the user with a flexible way to monitor and control the chillers at any place and time. The chiller is compatible with Modbus, BACnet and LonWorks and the display can seamlessly connect with the Building Automation System or the i-Vu Control network

Enhanced data analysis support

The SmartView™ control provides a convenient way to collect and utilize chiller information for data analysis. The Carrier lifecycle data management system further provides more details and offers opportunities to the users to continuously optimize the chiller or the system operation. The black box records all the data 15 minutes before and 1 minute after a serious alarm occurs.

SmartView™
Control

Enlarge your Floor Space

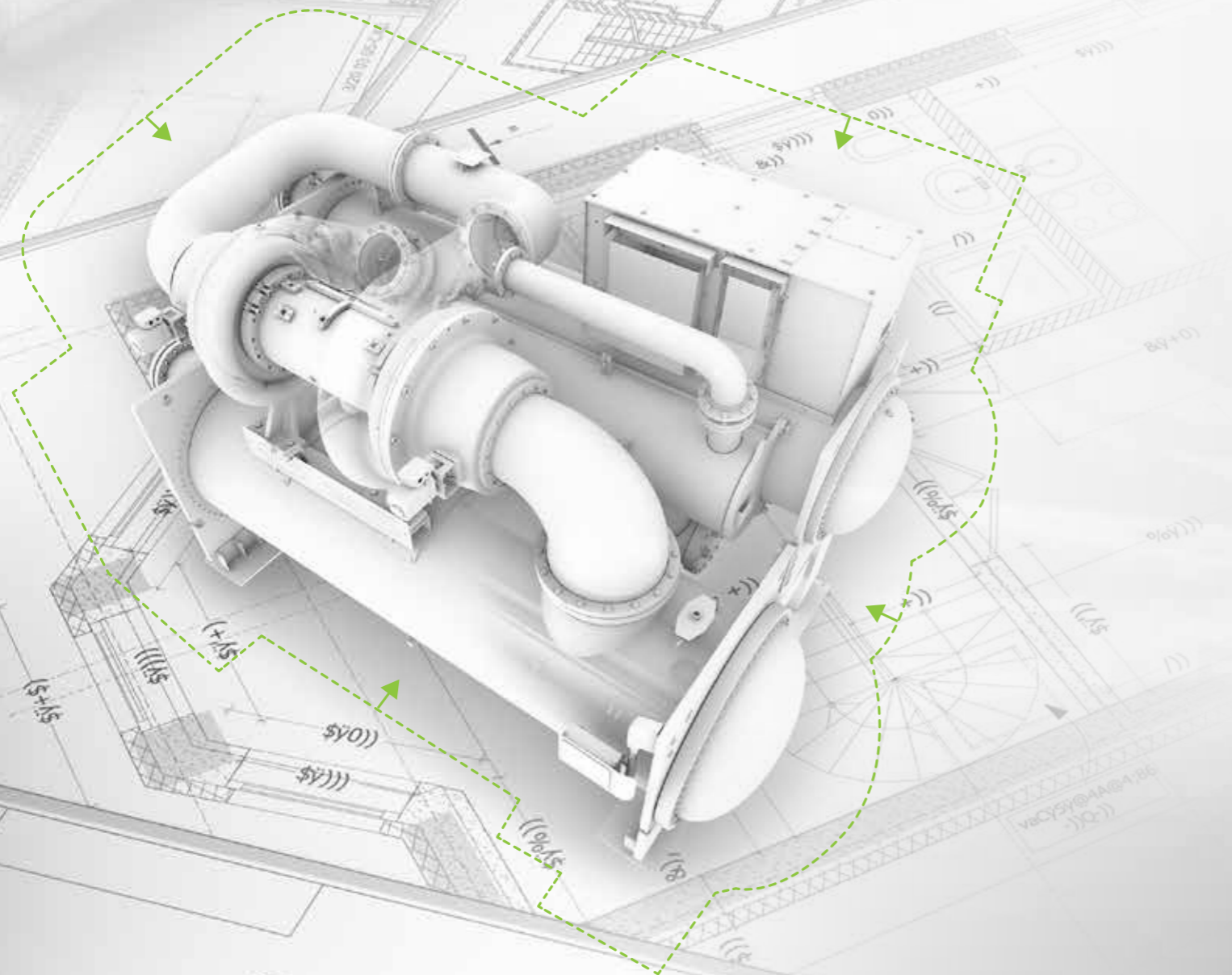

-15%
installation
footprint

4
corners
installation

3
adjustable
directions

5
pieces

Compact system design

The system layout of 19DV chillers and the crescent shape economizer is specifically designed to leverage the space between evaporator and condenser. Comparing the 19DV to conventional R-123 chiller, it saves up to 15% of plant installation space that can now be better used for your business operations.

Custom-positioned control panel

The layout of the chillers is flexible to your site's conditions because Carrier's patented re-locatable control panel can be installed at any corner. The panel position can be adjusted in 3 directions, to suit different space scenarios.

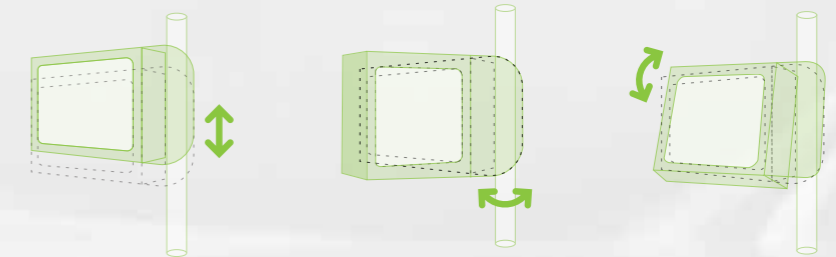

Multiple knockdown solutions

The knockdown design of 19DV chiller, that can be split into up to 5 pieces, make it ideal for installation in a limited space with a very limited door width and height, such as a retrofit project. Furthermore, lifting the chillers upwards on site becomes much easier.

Work in a Quieter Environment

The 19DV enables you to meet the 18001 standards recommended by Occupational Health and Safety Advisory Services (OHSAS).

Advanced aerodynamic design

The design of 19DV EquiDrive™ compressors are based on the aerodynamic theory of aircraft. This effectively minimizes the noise generated by the aero components.

Optimized compressor design

The hermetic motor driven without a gear system optimizes the flow channel and reduces the impeller speed by 60% when compared to the previous design so that the sound generated by refrigerant airflow is reduced.

Reduced noise levels at part-load operation

The impeller speed is turned down adaptively at part load by the Greenspeed™ intelligence to achieve better acoustic performance, for instance at night-time.

-8dB(A)

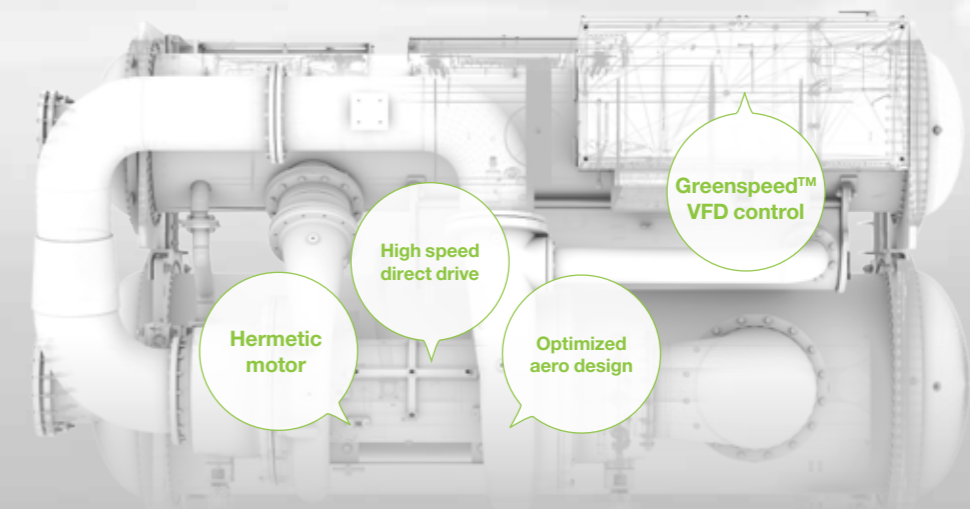

Assisting you in Achieving your Green Goals



Low GWP refrigerants

Carrier's range of low (<150) Global Warming Potential (GWP) refrigerants includes PUREtec™ R-1233zd(E), the low GWP of ~1, non-flammable and non-toxic solution that provides a safe and environmentally sustainable product which is an efficient replacement for R123, as suggested by the US Environment Protection Agency. In addition to using an excellent refrigerant, the falling film evaporator also means the 19DV chiller uses less refrigerant.

Substitute (Name Used in the Federal Register)	Refrigerant Being Replaced	Retrofit / New
R-410A	22, blends (22/142b)	N
R-407C	22, blends (22/142b)	R, N
R-507, R507A	22, blends (22/142b)	N
R-245fa	22, blends (22/142b)	R, N
Hot Shot 2	22, blends (22/142b)	R
R-1233zd(E)	123	N

* R-1233zd(E) approved by EPA SNAP

Lower carbon emissions

19DV chillers are designed to decrease the energy consumption and reduce the related CO₂ emissions.

If we take an example of one typical 2,400 Ton industrial project, the application of 19DV will help the user to save up to 212,024,000kWh of power consumption for the lifecycle of 25 years which is an equivalent of 16,503 Ton of CO₂ emissions.

All in one CITY

Office Building

19DV chillers with 11.8 IPLV.IP keep the optimal efficiency at any building load according to multiple factors including occupancy and climate.



Health Care

The 5% harmonic filter option enables a secured protection from the electromagnetic interference that endangers the safety of medical facilities.



Data Center

The 30s swift start makes 19DV chillers an ideal solution for resisting power failures. The high efficiency at full load leads to lower operating costs.



Luxury Hotel

19DV Chillers adapt to any conditions and offer optimal efficiency and reliable operation even when down to 10% low load.



Industry

Smart controls stabilize water temperature with precision, providing reliable chiller operations all year long.



Natural leadership commitment

Turn to the natural leader to bring you the next generation in air-conditioning technology. For over a century, Carrier has been pioneering safer, smarter and more sustainable solutions.

A worldwide weathermaker

As proven experts and innovators in commercial heating, ventilation and air conditioning, our solutions are found in some of the most advanced, sustainable buildings and prestigious installations around the world.

Customized value add

AdvanTE³C solution center is offering the customized solutions which provide the flexibility to integrate more building technologies on a centralized platform for greater system performance and more environmental benefits.



AquaEdge™ with PUREtec™ refrigerant and Greenspeed™ intelligence, the new generation of chillers, to deliver higher reliability, efficiency and sustainability, and to make the world a better place to live today and for the benefit of future generations.